

# GE Sensing

## The Next Generation Humidity Reference Standard

GE's Optica Series chilled mirror hygrometers offer National Institute of Standards and Technologies (NIST)–traceable humidity, temperature and pressure measurements for the connected generation. Now data is accessible from anywhere, any time, from within a browser over the Internet or from your intranet.

### Optica Measures

- Temperature
- Relative humidity (% RH)
- Dew/frost point (Td)
- Absolute humidity (m/v)
- Mass mixing ratio (m/m)
- Volume mixing ratio (v/v)

- Wet bulb (Tw)
- Enthalpy (h)
- Water vapor pressure (e)
- Pressure
- Alarm relays
- Analog outputs

Fundamental dew point measurement is a primary measurement used as a transfer standard for calibrating other humidity instruments and sensors. Chilled mirrors are also the sensors of choice when process and laboratory measurements call for high precision without long term drift. Optica may be used with five, fully interchangeable chilled mirror sensors to provide a measurement range from -112°F to 185°F (-80°C to 85°C) dew point with 0.36°F (0.2°C) or better accuracy. Inputs for a 100 Ω RTD and silicon-based piezoresistive pressure transducer ensure precision measurements, which are used to convert the dew point to any metric, English or user-defined unit of humidity measure.

## Optica™

Optica is a General Eastern product. General Eastern has joined other GE high-technology sensing businesses under a new name—GE Industrial, Sensing.



# GE Sensing

## Communications

- Ethernet port
- Java-based applet loads in web browsers
- Data logger 6 megabyte memory
- Recorded data uploads in ASCII format
- Exports to spreadsheets
- Real time "strip chart" graphing
- Color VGA or 4 x 40 matrix display

## Software

The Optica software is easy to navigate. Users select readout display, strip chart, analog output scale, digital communications, self-diagnostics, cleaning and data logging with intuitive pull-down menus. Setup values can be saved in memory and loaded anytime, either locally or from anywhere via the Ethernet port.

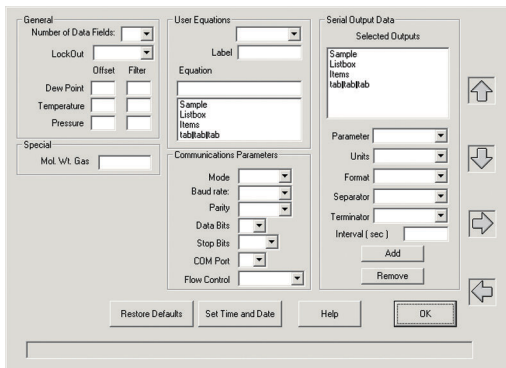

## In the Lab or on the Plant Floor

- Calibration labs
- Process control
- Clean rooms
- Environmental test chambers
- Precision HVAC monitoring and control
- Fuel cells

- Heat exchanger and refrigerant coil calorimeters
- Thermal processing/heat treating
- Semiconductor manufacturing
- Storage areas
- Pharmaceutical validation chambers
- Engine test cells and emissions testing
- Aircraft engines and turbines

## Functionality

The Optica simultaneously measures dew point, temperature and pressure. The analyzer is equipped with programmable math functions to produce custom units. In, exp +, -, x and / functions enable derived engineering units to be displayed, recorded and transmitted to data acquisition systems. The analyzer input channel is a standard 4 to 20 mA/0 to 5 VDC input, so the Optica can be connected to any type of process transmitter and be configured to display engineering units.



*"Plug and play" setup is easily accomplished with standard connectors for power, sensor and analog outputs.*

## Chilled Mirror Sensors Theory of Operation

GE's chilled mirror hygrometers are used in standards and metrology labs as well as in industrial applications where precise and repeatable humidity measurement and control is required. The inherent accuracy and long term stability provides many advantages over other types of humidity measurement technologies. Chilled mirrors fundamentally measure the dew or frost point temperature directly by controlling a reflective surface to an equilibrium temperature between dew/frost formation and evaporation, and precisely measuring the temperature of the mirror at this point.

# GE Sensing

GE's chilled mirrors consist of a small polished hexagonal rhodium, or platinum mirror attached to thermoelectric cooling module (TEC). The Optica analyzer's servo controller applies current to the TEC, which causes the mirror to cool. The mirror is illuminated with a regulated Gas emitter, which transmits light in the infrared spectrum. The light reflected by the mirror is received by a photodetector. When water vapor condenses on the mirror as water or frost (ice crystals), the light received by the photodetector is reduced due to scattering. This results in the servo controller reducing the power causing the mirror to slightly warm. The Optica's control system will modulate the amount of current flowing through the TEC to maintain a temperature where the rate of condensation and evaporation of water molecules and the mass of water on the mirror is constant. The resulting temperature of the mirror is then, fundamentally by definition, equal to the dew or frost point temperature. A precision four-wire platinum RTD imbedded in the mirror measures the temperature. The accuracy of the dew point measurement has been validated to an accuracy of  $\pm 0.36^{\circ}\text{F}$  ( $\pm 0.2^{\circ}\text{C}$ ) dew/frost point. The precision can also be enhanced to  $\pm 0.27^{\circ}\text{F}$  ( $\pm 0.15^{\circ}\text{C}$ ) dew/frost point.

Dry bulb temperature is measured with a precise four-wire 100  $\Omega$  platinum RTD and pressure is measured with a piezoresistive silicon pressure transducer. The dew/frost point and dry bulb RTD resistance signals are conditioned and amplified by the Optica monitor to display and transmit dew/frost point and temperature. The pressure sensor transmits an amplified 4 to 20 mA signal that is powered by the Optica. The cardinal measurements of dew/frost point, dry bulb temperature and pressure are used to calculate other humidity parameters such as relative humidity, wet bulb, mass mixing ratio, volumetric mixing ratio, absolute humidity, enthalpy and water vapor pressure values using psychometric equations.

The RTD sensor is imbedded in the chilled mirror and never comes in contact with the process or test environment. The wetted parts consist of the platinum or rhodium mirror, a stainless steel or mylar vapor barrier and epoxy sealant. The net result is drift-free humidity measurement designed to maintain accuracy specifications for many years.

Chilled mirrors require a nominal flow rate across the mirror to achieve the optimal dew/frost formation and response time. The sensor should either be installed in a duct with moving air or be equipped with a sampling pump. The optimum flow rate is 0.5 to 5 SCFH (0.25 to 2.5 L/min). GE provides sampling systems to temperature

condition, regulate the pressure and filter process air prior to reaching the chilled mirror. Our application engineers will discuss your application in detail and provide a recommendation for the system best suited to your needs.

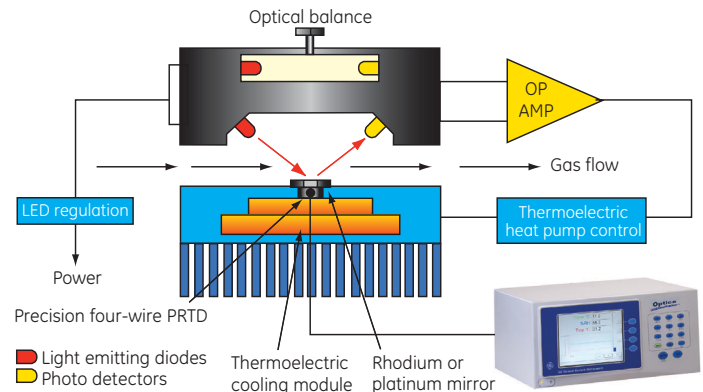

## Self Cleaning and Digital Control

For environments where physical contaminants such as dust, oil mist and pollen are present, the use of a sampling system with a filter media is recommended. The filter media must be hydrophobic so as to not absorb or release water vapor into the test stream. Over time the mirror can be etched or pitted by particulate, altering the light scattering characteristics. GE mirrors are field replaceable. The standard rhodium mirror may be upgraded to platinum for industrial applications.

GE developed a patented contamination compensation scheme called PACER<sup>®</sup> (Program Automatic Error Reduction). The PACER cycle may be initiated manually or by programming a timed cycle. The cycle starts by capturing the data (during the PACER cycle a constant value is transmitted) and cooling the mirror well below the dew point such that a thick dew layer forms on the mirror. The mirror is then rapidly heated. During the heating a significant amount of soluble and some non-soluble contamination is flash evaporated. The contamination left on the mirror tends to aggregate in dry islands or spots (much like a glass that comes out of a dishwasher). This process leaves approximately 85% of the mirror clean. The light signal received by the photodetector is compared against a reference LED/photodetector and the two signals are "balanced," effectively negating the effect of the residual contamination left on the mirror. The PACER cycle works very well, but eventually manual cleaning may be required. All of GE's chilled mirrors are accessible for

# GE Sensing

manual cleaning. Cleaning is a simple process consisting of wiping the mirror with a cotton swab wetted with cleaning solution or distilled water. (Distilled water is recommended as the final cleaning agent.)

GE developed Digiloop™ control to overcome the limitations of traditional analog PID (Proportional Integral and Derivative) control. Analog temperature control produces oscillations particularly at high or trace humidity levels. It is difficult to apply self-tuning or PID constants to analog control loops, which are over damped or under damped. Digiloop utilizes digital sampling and feed-forward control by taking time-based samples when the dew point is within a predetermined proportional band. By recording the oscillations, the digital control effectively predicts the magnitude of change and adjusts the current to the thermoelectric cooling module, which steps the mirror temperature in 0.09°F (0.05°C) increments. This results in a significantly improved control and dew point precision.

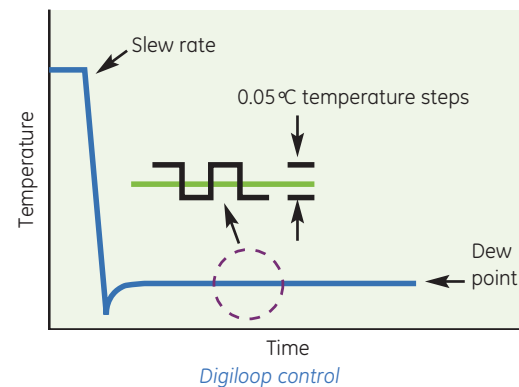
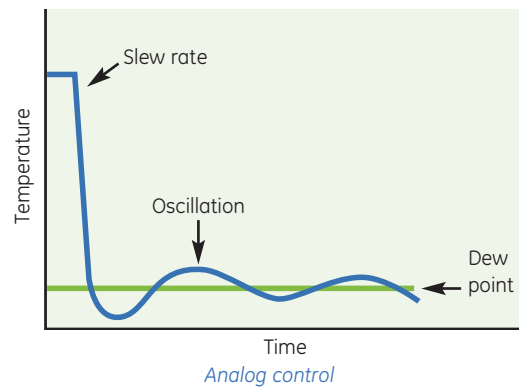
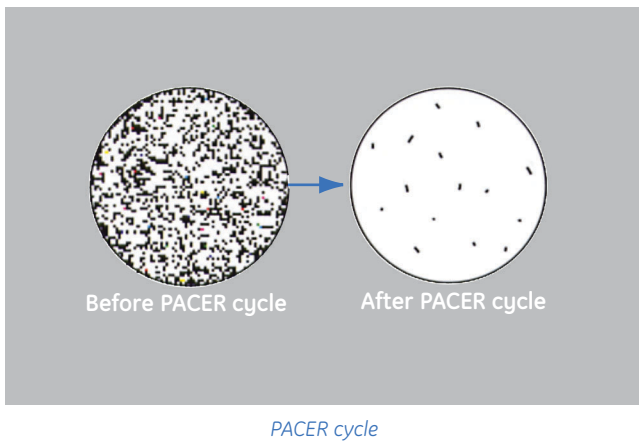
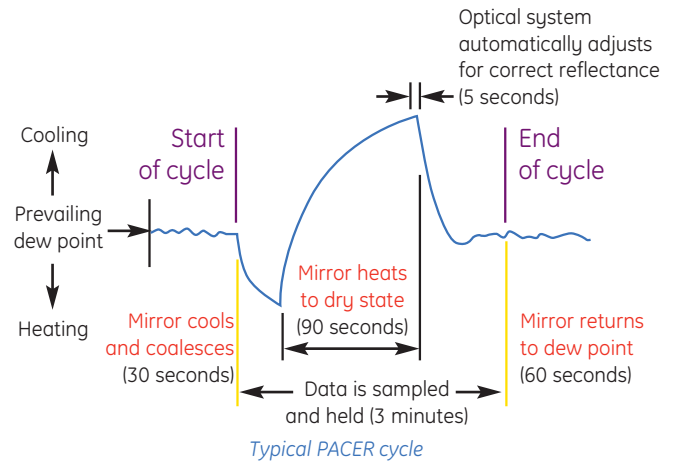

# Optica Specifications

## Models

- Color VGA with data logger and Ethernet communications available in bench, rack or wall mount styles
- 4 x 40 dot matrix available in bench, rack or wall mount styles

## Power

95 to 265 VAC, 50/60 Hz, 200 watts

## Electrical I/O

IEC-style AC receptacle (bench mount), screw terminal block (wall mount), multipin chilled mirror and temperature sensor/cable connectors, screw terminals for analog outputs, DB-9 for RS232 and 10 base-T for Ethernet\*

## Measured Parameters

Dew point, temperature and 4 to 20 mA/0 to 5 VDC

## Calculated Parameters

Relative humidity, wet bulb, mass mixing ratio, volumetric mixing ratio, absolute humidity, water vapor pressure and enthalpy in English and metric units, as well as user-configured units

## Inputs

1/3 Class A DIN 43760, 100  $\Omega$  RTD and dew/frost point and dry bulb temperature. Loop powered 4 to 20 mA DC at 500  $\Omega$  maximum load

## Accuracy

System accuracy  $\pm 0.36^\circ\text{F}$  ( $\pm 0.2^\circ\text{C}$ ) for dew/frost point,  $\pm 0.27^\circ\text{F}$  ( $\pm 0.15^\circ\text{C}$ ) for temperature, 0.5% full scale (FS) for pressure

## Range

Governed by sensor

## Hysteresis

Negligible

## Sensitivity

0.1% FS

## A/D

16 bit

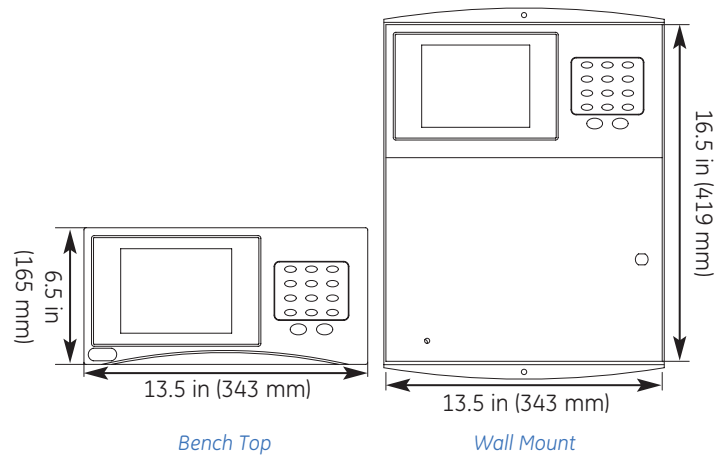

## Data Logger Memory

6 megabytes\*

## Display

1/4 color VGA enables up to six parameters to be displayed or 4 x 40 dot matrix enables three parameters to be displayed

## Operating Temperature

32°F to 122°F (0°C to 50°C)

## Cooling Rate

0.27°F (1.5°C)/sec typical above 32°F (0°C)

## Digital Interface

RS232 port, Ethernet port\*

## Digital Output Format

Data ASCII text, Ethernet java applet password protected\*

## TCP/IP Address

User programmable\*

## Analog Outputs

(2) 4 to 20 mA and 0 to 5 VDC, user configurable and scalable

## Analog Outputs

(2) 5 A at 250 V, form C, (SPDT) relays

## Enclosure

Benchtop: Type 1

Wall Mount: Type 4

## Weight

Benchtop: 8 lb (3.6 kg)

Wall Mount: 10 lb (4.5 kg)

\*Feature available with VGA models only

# 1111H Single-Stage Chilled Mirror Specifications

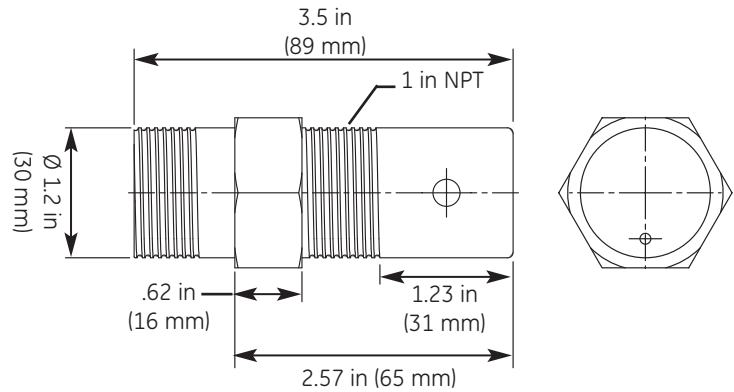

## Sensing Element

Four-wire 1/3 Class A DIN 43760 RPT, 100  $\Omega$  @ 32°F (0°C)

## Dew/Frost Point Accuracy

Standard:  $\pm 0.36^\circ\text{F}$  ( $\pm 0.2^\circ\text{C}$ )

Optional:  $\pm 0.27^\circ\text{F}$  ( $\pm 0.15^\circ\text{C}$ )

## Sensitivity

$> 0.05^\circ\text{F}$  ( $> 0.03^\circ\text{C}$ )

## Repeatability

$\pm 0.09^\circ\text{F}$  ( $\pm 0.05^\circ\text{C}$ )

## Hysteresis

Negligible

## Cooling Stages

Single stage thermoelectric cooling (TEC) module

## Auxiliary Cooling

Not applicable

## Depression

81°F (45°C) at 77°F (25°C) dry bulb and atmospheric pressure

## Typical Measurement Range

5°F to 77°F (-15°C to 25°C) dew/frost point (Td) in air @ 77°F (25°C) and atmospheric pressure. Equivalent to 5% to 100% RH.

Other humidity parameters based on calculations.

## Sample Flow

0.5 to 5.0 SCFH (0.25 to 2.5 L/min)

## Operating Temperature

5°F to 176°F (-15°C to 80°C)

## Pressure

-3 to 200 psig (0.8 to 15 bar)

## Power

Derived from Optica

## Sensor Body

Epoxy-coated aluminum

## Filter

Polytetrafluoroethylene (PTFE) filter (standard on 1111H-GE)

## Mirror

Standard: Rhodium-plated copper

Optional: Solid platinum

## Sensor Wetted Material

Aluminum, copper, mylar, PTFE, rhodium or platinum

## Vapor Barrier

Mylar

## Electrical Connector

MS-style multipin connector

## Weight

1 lb (1.4 kg) net

## Accessories

**MB-11** Wall mounting bracket

**PTFE-GE** PTFE filter

**P** Platinum mirror

**X** Enhanced accuracy  $\pm 0.27^\circ\text{F}$  ( $\pm 0.15^\circ\text{C}$ ) Td

**O111D** Pressure boss (1111H only)

# D2 Two-Stage Chilled Mirror Specifications

## Sensing Element

Four-wire 1/3 Class A DIN 43760 RPT, 100  $\Omega$  @ 32°F (0°C)

## Dew/Frost Point Accuracy

Standard:  $\pm 0.36^\circ\text{F}$  ( $\pm 0.2^\circ\text{C}$ )

Optional:  $\pm 0.27^\circ\text{F}$  ( $\pm 0.15^\circ\text{C}$ )

## Sensitivity

$> 0.05^\circ\text{F}$  ( $> 0.03^\circ\text{C}$ )

## Repeatability

$\pm 0.09^\circ\text{F}$  ( $\pm 0.05^\circ\text{C}$ )

## Hysteresis

Negligible

## Cooling Stages

Two-stage TEC module

## Auxiliary Cooling

Not applicable

## Depression

117°F (65°C) at 77°F (25°C) and atmospheric pressure

## Typical Measurement Range

31°F to 77°F (-35°C to 25°C) dew/frost point (Td) in air @ 77°F (25°C) and atmospheric pressure. Equivalent to 0.7% to 100% RH.

Other parameters based on calculations.

## Sample Flow

0.5 to 5.0 SCFH (0.25 to 2.5 L/min)

## Operating Temperature

-13°F to 185°F (-25°C to 85°C)

## Pressure

150 psig (11 bar) maximum

## Power

Derived from Optica monitor

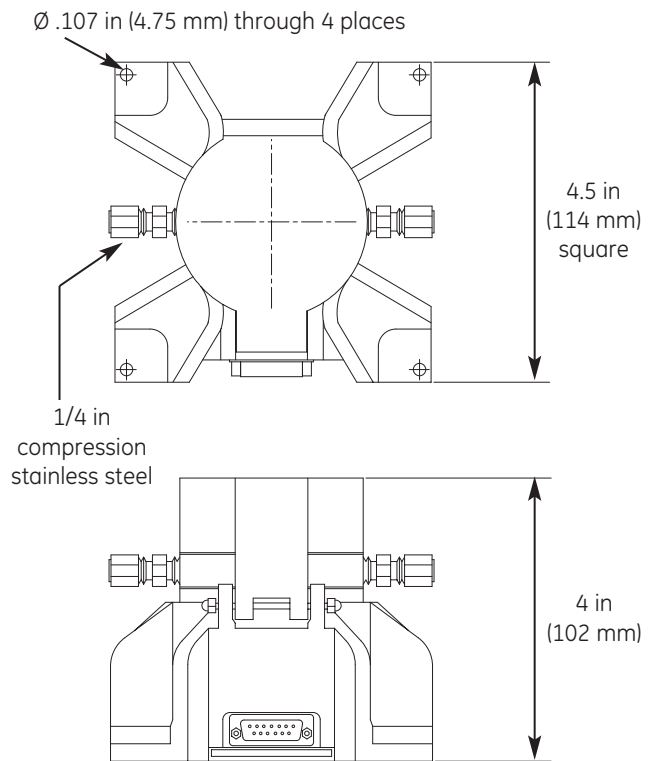

## Sensor Body

Cast aluminum with 314 stainless steel flow cell

## Mirror

Standard: Rhodium-plated copper

Optional: Solid platinum

## Sensor Wetted Material

302, 316 stainless steel, silicone o-ring, BK-7 glass, rhodium or platinum mirror

## Vapor Barrier

Stainless steel

## Inlet/Outlet

1/4 in OD tubing compression fittings

## Electrical Connector

Sub-D 15-pin connector mates with 2130 cable

## Weight

4 lb (1.8 kg) net

## Accessories

P Platinum mirror

X Enhanced accuracy  $\pm 0.27^\circ\text{F}$  ( $\pm 0.15^\circ\text{C}$ ) Td



# 1211H Two-Stage Chilled Mirror Specifications

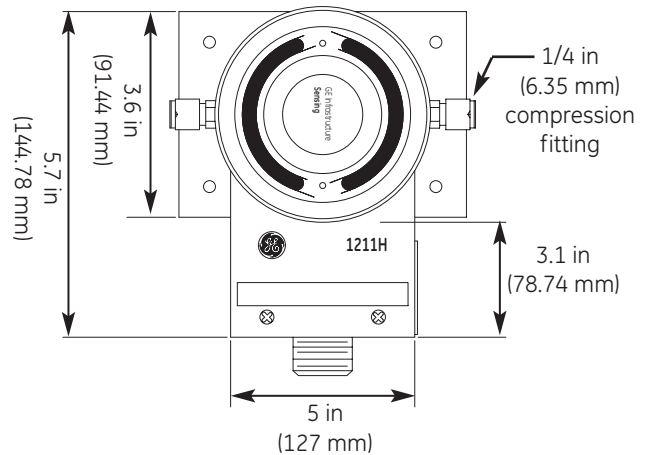

## Sensing Element

Four-wire 1/3 Class A DIN 43760 RPT, 100  $\Omega$  @ 32°F (0°C)

## Dew/Frost Point Accuracy

Standard:  $\pm 0.36^\circ\text{F}$  ( $\pm 0.2^\circ\text{C}$ )

Optional:  $\pm 0.27^\circ\text{F}$  ( $\pm 0.15^\circ\text{C}$ )

## Sensitivity

$> 0.05^\circ\text{F}$  ( $> 0.03^\circ\text{C}$ )

## Repeatability

$\pm 0.09^\circ\text{F}$  ( $\pm 0.05^\circ\text{C}$ )

## Hysteresis

Negligible

## Cooling Stages

Two-stage TEC module

## Depression

117°F (65°C) at 77°F (25°C) and atmospheric pressure

## Typical Measurement Range

31°F to 77°F (-35°C to 25°C) dew/frost point (Td) in air @ 77°F (25°C) and atmospheric pressure. Equivalent to 0.7% to 100% RH.

Other parameters based on calculations.

## Sample Flow

0.5 to 5.0 SCFH (0.25 to 2.5 L/min)

## Operating Temperature

5°F to 212°F (-15°C to 100°C)

## Pressure

300 psig (21 bar) maximum

## Power

Derived from Optica

## Sensor Body

Cast aluminum with 314 stainless steel flow cell

## Mirror

Standard: Rhodium-plated copper

Optional: Solid platinum

## Sensor Wetted Material

302, 316 stainless steel, silicone o-ring, BK-7 glass, rhodium or platinum mirror

## Vapor Barrier

Mylar (upgradeable to stainless steel)

## Inlet/Outlet

1/4 in OD tubing compression fittings

## Electrical Connector

MS-style multipin connector mates with 2120 cable

## Weight

4 lb (1.8 kg) net

## Accessories

- P Platinum mirror
- X Enhanced accuracy  $\pm 0.27^\circ\text{F}$  ( $\pm 0.15^\circ\text{C}$ ) Td
- S Stainless steel vapor barrier



# SIM-12 Heated Two-Stage Chilled Mirror Specifications

## Sensing Element

Four-wire 1/3 Class A DIN 43760 RPT, 100  $\Omega$  @ 32°F (0°C)

## Dew/Frost Point Accuracy

Standard:  $\pm 0.36^\circ\text{F}$  ( $\pm 0.2^\circ\text{C}$ )

Optional:  $\pm 0.27^\circ\text{F}$  ( $\pm 0.15^\circ\text{C}$ )

## Sensitivity

$>0.05^\circ\text{F}$  ( $>0.03^\circ\text{C}$ )

## Repeatability

$\pm 0.09^\circ\text{F}$  ( $\pm 0.05^\circ\text{C}$ )

## Hysteresis

Negligible

## Cooling Stages

Two-stage TEC module

## Auxiliary Cooling

Not applicable

## Depression

153°F (85°C) at 167°F (75°C) body temperature and atmospheric pressure

## Typical Measurement Range

14°F to 167°F (-10°C to 75°C) dew/frost point (Td) in air @ 167°F (75°C) body temperature in 77°F (25°C) ambient temperature and atmospheric pressure. Equivalent to 0.7% to 100% RH.

Other parameters based on calculations.

## Sample Flow

0.5 to 5.0 SCFH (0.25 to 2.5 L/min)

## Operating Temperature

5°F to 212°F (-15°C to 100°C)

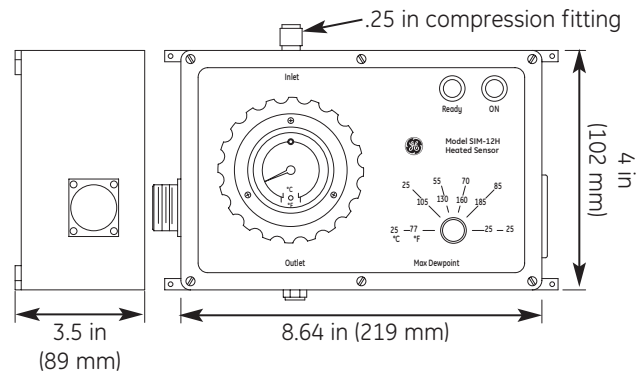

## Heater Control

Thermostatically controlled. Set point of 77°F (25°C), 104°F (40°C), 131°F (55°C), 158°F (70°C), 185°F (85°C) and 212°F (100°C)

## Pressure

50 psig (4.5 bar) maximum  
100/115/230 VAC, 50/60 Hz, 75 watts

## Sensor Body

Cast aluminum with 314 stainless steel flow cell

## Sensor Wetted Material

302, 316 stainless steel, silicone o-ring, BK-7 glass, rhodium or platinum mirror

## Mirror

Standard: Rhodium plated copper

Optional: Solid platinum

## Vapor Barrier

Mylar (upgradeable to stainless steel)

## Electrical Connector

MS-style multipin connector

IEC receptacle for AC power

## Weight

7 lb (3.2 kg) net

## Accessories

**P** Platinum mirror

**X** Enhanced accuracy  $\pm 0.27^\circ\text{F}$  ( $\pm 0.15^\circ\text{C}$ ) Td

**S** Stainless steel vapor barrier

**HSS-12** Heated sampling system. SIM-12 heated chilled mirror, SIM-HFT heated filter module and SIM-HFM heated flowmeter mounted on a plate with SIM-HSL heated sample line.

GE  
Sensing

# 1311-DR Four-Stage Chilled Mirror Specifications

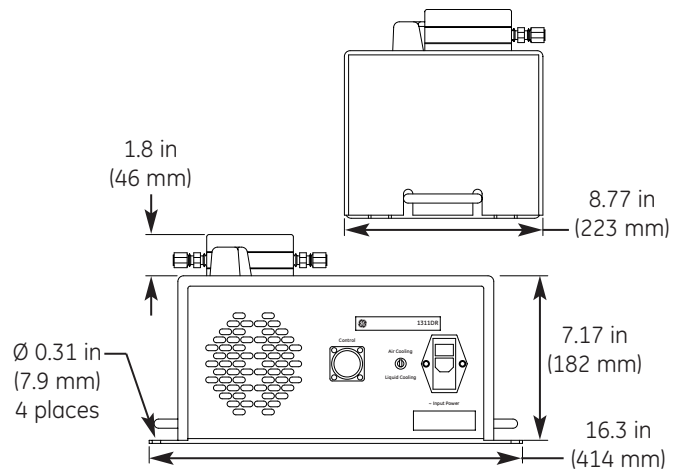

## Sensing Element

Four-wire 1/3 Class A DIN 43760 RPT, 100  $\Omega$  @ 32°F (0°C)

## Dew/Frost Point Accuracy

Standard:  $\pm 0.36^\circ\text{F}$  ( $\pm 0.2^\circ\text{C}$ )

Optional:  $\pm 0.27^\circ\text{F}$  ( $\pm 0.15^\circ\text{C}$ )

## Sensitivity

$> 0.05^\circ\text{F}$  ( $> 0.03^\circ\text{C}$ )

## Repeatability

$\pm 0.09^\circ\text{F}$  ( $\pm 0.05^\circ\text{C}$ )

## Hysteresis

Negligible

## Cooling Stages

Four-stage TEC module

## Auxiliary Cooling

Liquid cooling jacket

## Depression, Air Cooled

171°F (95°C) at 77°F (25°C) and atmospheric pressure

## Depression, Liquid Cooled

189°F (105°C) with 59°F (15°C) cooling water

## Typical Measurement Range

- 85°F to 77°F (-65°C to 25°C) dew/frost point (Td) in air @ 77°F (25°C) and atmospheric pressure.
- 103°F to 59°F (-75°C to 15°C) in liquid-cooled mode with 59°F (15°C) coolant.

Other parameters based on calculations.

## Sample Flow

0.5 to 5.0 SCFH (0.25 to 2.5 L/min)

## Operating Temperature

32°F to 95°F (0°C to 35°C)

## Pressure

300 psig (22 bar) maximum

## Power

100/115/230 VAC, 50/60 Hz, 300 watts

## Sensor Body

Cast aluminum with 314 stainless steel flow cell

## Mirror

Standard: Rhodium-plated copper

Optional: Solid platinum

## Sensor Wetted Material

302, 316 stainless steel, silicone o-ring, BK-7 glass, rhodium or platinum mirror

## Vapor Barrier

Mylar (upgradeable to stainless steel)

## Inlet/Outlet

1/4 in (6 mm) OD tubing compression fittings

## Electrical Connector

MS-style multipin connector mates

IEC receptacle for AC power

## Weight

34 lb (16 kg) net

## Accessories

- |   |  |
|---|--|
| P | Platinum mirror  |
| X | Enhanced accuracy $\pm 0.27^\circ\text{F}$ ( $\pm 0.15^\circ\text{C}$ ) Td |
| S | Stainless steel vapor barrier  |

# 1311-XR Five-Stage Chilled Mirror Specifications

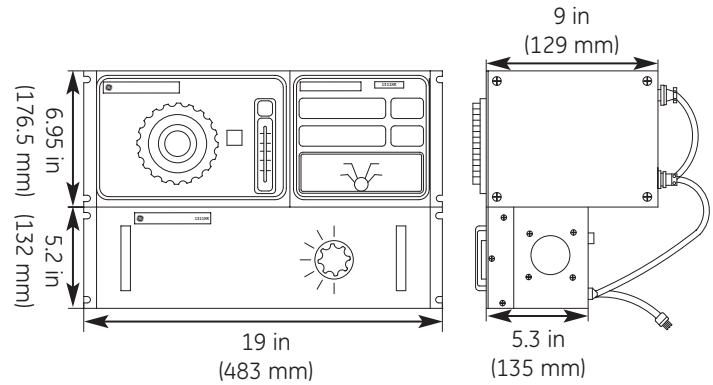

## Sensing Element

Four-wire 1/3 Class A DIN 43760 RPT, 100  $\Omega$  @ 32°F (0°C)

## Dew/Frost Point Accuracy

Standard:  $\pm 0.27^\circ\text{F}$  ( $\pm 0.15^\circ\text{C}$ )

## Sensitivity

$> 0.05^\circ\text{F}$  ( $> 0.03^\circ\text{C}$ )

## Repeatability

$\pm 0.09^\circ\text{F}$  ( $\pm 0.05^\circ\text{C}$ )

## Hysteresis

Negligible

## Cooling Stages

Five-stage TEC module

## Auxiliary Cooling

Liquid cooling jacket

## Depression, Liquid Cooled

202°F (112°C) with 59°F (15°C) cooling water

## Typical Measurement Range

-112°F to 59°F (-80°C to 15°C) dew/frost point (Td) in air @ 77°F (25°C) and atmospheric pressure with 59°F (15°C) cooling water.

Other parameters based on calculations.

## Sample Flow

0.5 to 5.0 SCFH (0.25 to 2.5 L/min)

## Operating Temperature

32°F to 95°F (0°C to 35°C)

## Pressure

0 to 100 psig (1 to 8 bar)

## Power

115/230 VAC, 50/60 Hz, 700 watts

## Sensor Body

314 stainless steel

## Mirror

Standard: Rhodium-plated copper

Optional: Solid platinum

## Sensor Wetted Material

302, 316 stainless steel, silicone o-ring, BK-7 glass, rhodium or platinum mirror

## Vapor Barrier

Mylar (upgradeable to stainless steel)

## Inlet/Outlet

1/4 in OD tubing compression fittings

## Electrical Connector

MS-style multipin connector

IEC receptacle for AC power

## Weight

50 lb (26 kg) net

## Accessories

P Platinum mirror

S Stainless steel vapor barrier

GE  
Sensing

# T-100 Four-Wire PRTD Temperature Mirror Specifications

## Sensing Element

Four-wire 1/3 Class A DIN 43760 RPT, 100  $\Omega$  @32°F ( 0°C)

## Accuracy

System at 25°C

Standard:  $\pm 0.27^\circ\text{F}$  ( $\pm 0.15^\circ\text{C}$ )

Optional:  $\pm 0.18^\circ\text{F}$  ( $\pm 0.1^\circ\text{C}$ )

## Measurement Range

-148°F to 212°F (-100°C to 100°C)

## Response Time

7 seconds for 77°F to 158°F (25°C to 70°C) step change in fluid

## Sensor Body

Stainless steel sheath

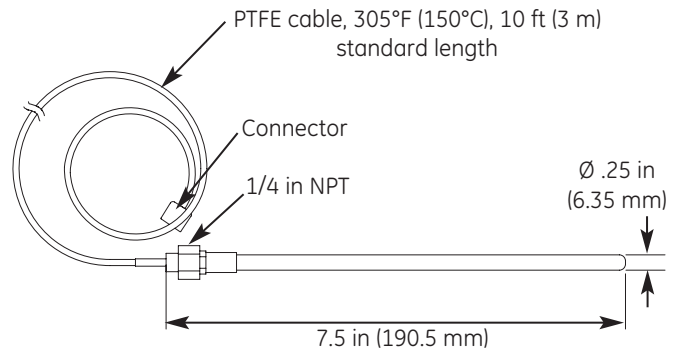

## Cable

PTFE insulation rated to 302°F ( 150°C). 10 ft (3 m) standard length.

## Fittings

Adjustable 1/4 in NPT stainless steel compression fitting

## Strain Relief

Stainless steel spring

## Power

Low voltage derived from Optica

## Weight

2 lb (0.9 kg) net

## Options

Additional cable length

# PT Series Pressure Transducer Specifications

## Sensing Element

Micro-machined silicon strain gauge

## Accuracy

System at 77°F (25°C),  $\pm 0.5\%$  of full scale

## Range PT-30A

0 to 30 psia (0 to 2 bar)

## Range PT-300A

0 to 300 psia (0 to 21 bar)

## Response Time

1 second for 90% of steady state (10% to 90% change)

## Operating Ranges

- -4°F to 176°F (-20°C to 80°C) ambient temperature
- -13°F to 248°F (-25°C to 120°C) process temperature

## Temperature Effect

<1% FS on accuracy from 14°F to 122°F (-10°C to 50°C)  
for pressure 6 psi (0.4 bar)

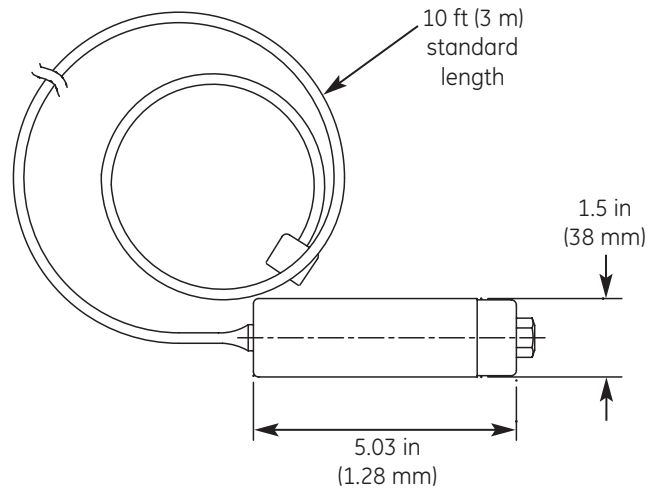

## Power

9 to 30 VDC. Derived from Optica monitor.

## Sensor Body Material

316 stainless steel

## Sensor Wetted Material

316 stainless steel and Hastelloy diaphragm

## Cable

PVC insulation. 10 ft (3 m) standard length process connection 1/4 in F-NPT.

## Weight

4 lb (1.8 kg) net

# SSM Sampling System Specifications

## Enclosure

Polycarbonate

## Fittings

Brass 1/4 in OD tubing

## Compression Internal Tubing

Impolene

## Rotameter

0.5 to 5 SCFH (0.2 to 2 L/min)

## Maximum Vacuum

-98 in (-250 mm) of Hg

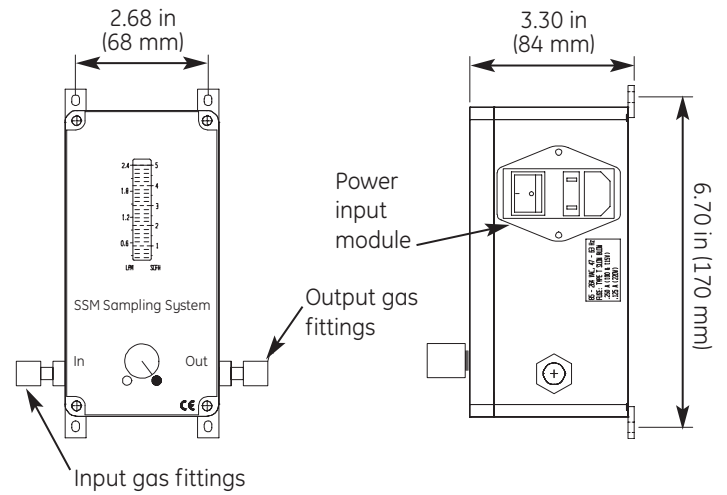

## Free Air Displacement

14 SCFH (6.5 L/min)

## Maximum Temperature

100°F (38°C)

## Power

95 to 265 VAC, 50/60 Hz, 15 watts

# Appendix

## 1111H Single-Stage Chilled Mirror Sensor Body Temperature °C

45°C depression

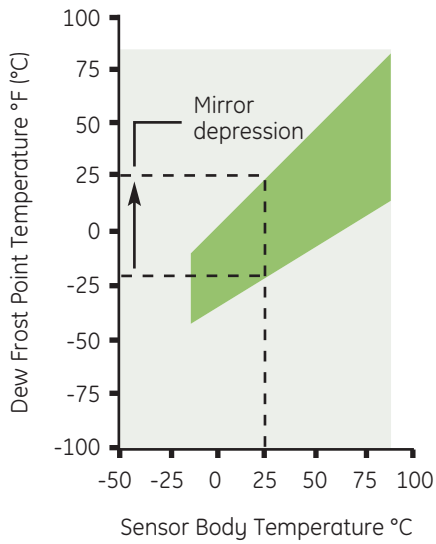

## 1211H Two-Stage Chilled Mirror Sensor Body Temperature °C

65°C depression

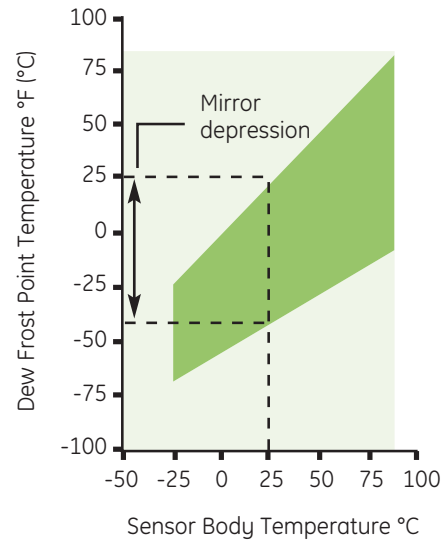

## D2 Two-Stage Chilled Mirror Sensor Body Temperature °C

65°C depression

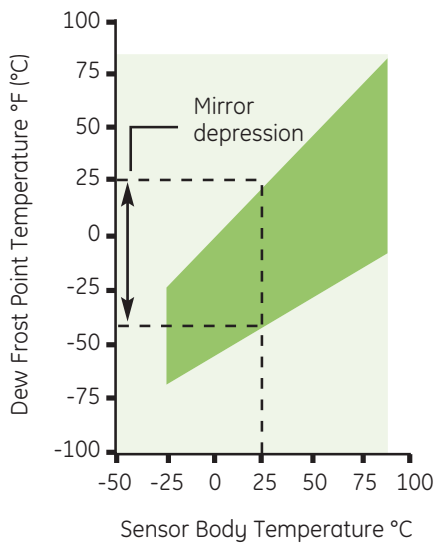

## SIM-12 Heated Two-Stage Chilled Mirror Sensor Body Temperature °C

65°C depression

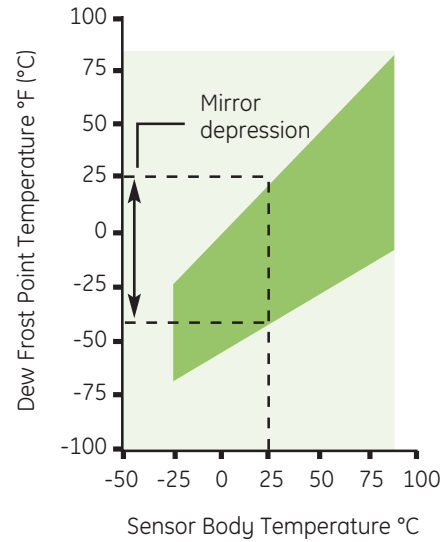



# Appendix

## 1311-DR Four-Stage Chilled Mirror Sensor Body Temperature °C

95°C depression

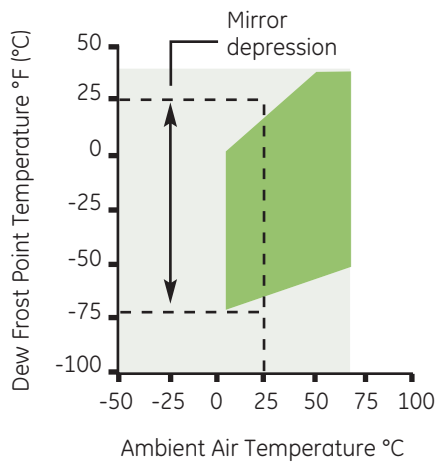

## 1311-XR Five-Stage Chilled Mirror Sensor Body Temperature °C

112°C depression

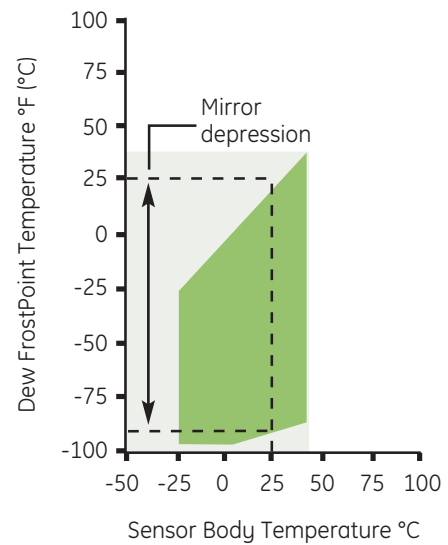

# Accessories

## BF-10DX General Purpose Filter

Recommended for dew points  $\geq 32^{\circ}\text{F}$  ( $\geq 0^{\circ}\text{C}$ )

### Materials

Anodized aluminum head, nylon bowl, nylon internals, Buna-N Seals

### Fittings

1/4 in compression

### Temperature

$-150^{\circ}\text{F}$  to  $220^{\circ}\text{F}$  ( $-101^{\circ}\text{C}$  to  $104^{\circ}\text{C}$ )

### Filter

Borosilicate glass

### Porosity

93% of particles over  $0.1\ \mu\text{m}$

### Pressure

150 psig (10 bar) maximum

### BF-12SS

Box of 10 replacement filter elements

## BF-12SS Stainless Steel Filter

Recommended for dew points  $\leq 32^{\circ}\text{F}$  ( $\leq 0^{\circ}\text{C}$ )

### Materials

316 stainless steel head, bowl and internals. Viton seals

### Fittings

1/4 in (6 mm) compression

### Temperature

$-150^{\circ}\text{F}$  to  $220^{\circ}\text{F}$  ( $-101^{\circ}\text{C}$  to  $104^{\circ}\text{C}$ )

### Filter

Borosilicate glass

### Porosity

93% of particles over  $0.1\ \mu\text{m}$

### Pressure

340 bar (5000 psig) maximum

### BF-12SS

Box of ten replacement filter elements

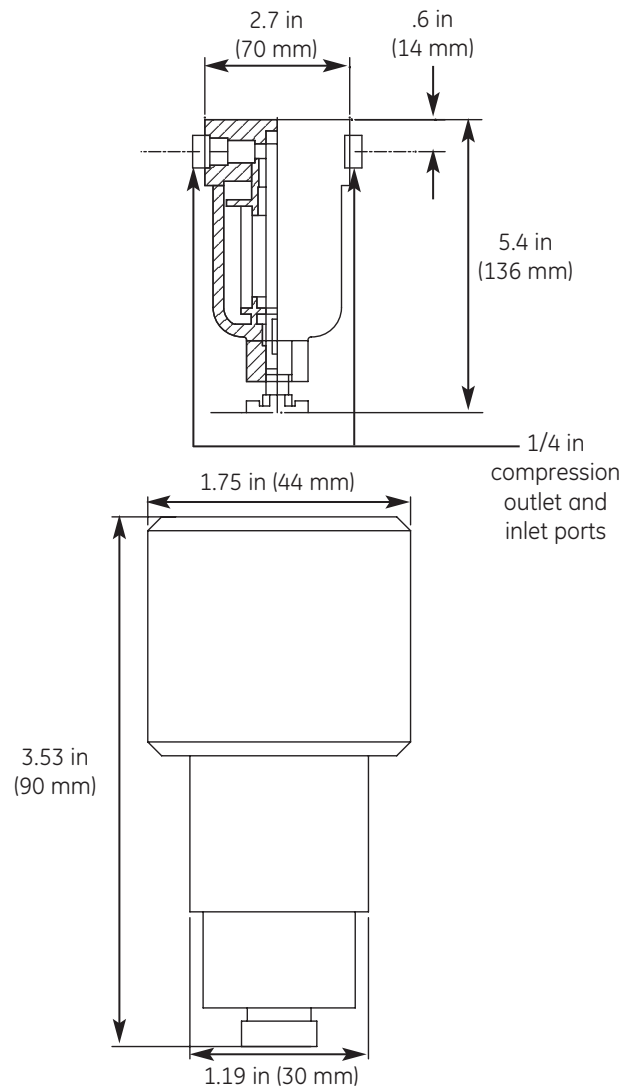

## FM-1 Rotameter/Needle Valve

### Materials

Clear acrylic body, Buna-N Seals, black glass float, brass valves

### Fittings

1/4 in compression

### Range

0.5 to 5 SCFH (0.2 to 2 L/min)

### Pressure

100 psig (6 bar) maximum

### Temperature

$150^{\circ}\text{F}$  ( $65^{\circ}\text{C}$ ) maximum

# Ordering Code Guide



## Optica Monitor

### Color VGA Display With Logger/Ethernet

- A** Benchtop
- B** Benchtop with rack mount bracket
- C** Wall mount

### Four-color, 40 Alphanumeric Display

- D** Benchtop
- E** Benchtop with rack mount bracket
- F** Wall mount

### Optica Channel One

- 1** Unit to be sold with new chilled mirror (see sensor section)
- 2** Use the existing D2 (conversion cable 2160 required)
- 3** Use with existing 1111H, 1211H, SIM-12H and 1311DR (conversion cable 2160 required)
- 4** Use with existing 1311XR (conversion cable 2140 required)

### Default Code

- 0** Default code

## Chiller Mirror Cable

### Cable Type

- 0** No cable required
- C** Adaptor cable for existing sensor/cable installation 2 ft (.61 m)
- A** 10 ft (3 m) standard length
- X** Specify length in ft (m)

- 2120** For use with 1111H, 1211H, SIM12, HSS-12, 1311DR sensors
- 2130** For use with D2
- 2140** For use with 1311XR
- 2150** For use with Optica CCD sensor
- 2160** Adaptor cable for sensors except 1311XR 2 ft (0.61 mm)
- 2170** Adaptor cable for 1311XR 2 ft (0.61 mm)

## Chilled Mirror Sensor

### Sensor

- 0** No sensor
- A** 1111H
- B** 1111H-GE
- C** D2
- D** 1211H

### SIM-12

- E** 100 VAC
- F** 115 VAC
- G** 230 VAC

### HSS-12

- H** 100 VAC
- J** 115 VAC
- K** 230 VAC

### 1311DR

- L** 100 VAC
- M** 115 VAC
- N** 230 VAC

### 1311XR

- P** 100 VAC
- Q** 115 VAC
- R** 230 VAC

# Ordering Code Guide

## Accuracy And Mirror

- 1 **S/R/M** standard accuracy, rhodium mirror, mylar vapor barrier
- 2 **S/P/M** standard accuracy, platinum mirror, mylar vapor barrier
- 3 **S/P/P** standard accuracy, platinum mirror, stainless steel vapor barrier
- 4 **X/R/M** enhanced accuracy, rhodium mirror, mylar vapor barrier
- 5 **X/P/M** enhanced accuracy, platinum mirror, mylar vapor barrier
- 6 **X/P/P** enhanced accuracy, platinum mirror, stainless steel vapor barrier
- 7 **S/R/P** standard accuracy, rhodium mirror, stainless steel vapor barrier (D2)
- 8 **X/R/P** enhanced accuracy, rhodium mirror, stainless steel vapor barrier (D2)
- 9 **S/P/P** standard accuracy, platinum mirror, stainless steel vapor barrier (D2)

## Temperature Sensor

### Sensor

- 0 No temperature sensor
- A T-100 with 10 ft (3 m) cable (standard accuracy)
- B T-100 with 10 ft (3 m) cable (enhanced accuracy)
- X T-100 with build to fit cable (standard accuracy)
- Z T-100 with 10 ft (3 m) cable (enhanced accuracy)

### Pressure Sensors

- 0 No pressure sensor
- A PT-30A 10 ft (3 m) cable (standard)
- B PT-30A build-to-fit cable
- X PT-300A 10 ft (3 m) cable (standard)
- Z PT-300A build-to-fit cable